

## SilverNugget N3-MX – X Series Controller

The SilverNugget™ N3-MX servo motor controller includes a controller/indexer, digital driver, active power clamp, and cabling to drive 3<sup>rd</sup> party NEMA 34 frame bipolar microstep motors with high resolution encoders. The SilverNugget has two integrated cables for interfacing with the primary encoder as well as the microstep motor. Serial communications and IO, as well as processor power are accessed through a High Density DB15 connector. CANopen is available on a separate DB 9 connector. Power and external Clamp resistor are available through a 5 pin 5W5 connector.

The 15 pin SMI interface includes 7 I/O, all of which support both LVTTTL and analog signals, and one of which also supports 0 to 10v analog input. 24v NPN/PNP inputs are accomplished by configuring the internal pull up/down resistor, which is configurable on each input. See [TD091](#) for details. A hardware drive enable are also included. Communication is available via CANopen and RS-485 serial, which may be operated simultaneously. The driver is rated to 20A continuous per phase. The system is designed for use at +12 to +72 VDC for driver power and 12-48v for processor power.

The X series SilverNugget includes dual internal clamp circuits. An external primary clamp allows the clamp resistor to be connected externally to handle the required power level. A secondary internal clamp comes on at a slightly higher internal voltage to protect the driver if the primary clamp is not connected, and for those low inertia designs and or lower speeds, or which are not back-driven, the 50w internal clamp may eliminate the need for an external clamp resistor, according to the application. (Note: Dump resistors are 50W average, allow up to 250W for up to 5 seconds). The internal clamp may also be bypassed for use with batteries to allow capture of regenerated power.

**Requires QuickControl v6.22 or greater to initialize and program controller.**

## System Overview

### Point-to-Point Moves

- Relative or Absolute
- Velocity or Time Based
- S-Curve

### Advanced Motion Profile Moves

- Profile Move Commands
- Register Based
  - Position/Accel/Decel/Velocity
  - Modify On-the-Fly

### Input/Output

- 7 LVTTTL Digital I/O
  - Bi-Directional
  - Set While In Motion
  - 24V NPN/PNP inputs [TD091](#)
- 7 Analog Inputs (Joystick)
- 1 Analog 0-10v Input
- 1 Output supports PWM out
- 1 Input supports PWM in
- Programmable Logic Switch out
- Secondary Encoder In
- Encoder Out (single ended and differential available)

### Program and Data Storage

- 32K Non-Volatile Memory
- 2000-3000 Program Lines
- Expanded 8191 word program buffer
- 4K User Registers
- User Data Examples
  - CAM Tables
  - Motion Profiles
  - Lookup Tables

### Electronic Gearing/Camming

- Follow External Signals
  - Encoder (A/B Quadrature)
  - Step and Direction
- Gearing plus Trapezoid motion
- Electronic Cam
  - Import Cam Table from File
- Gearing with extended precision:
  - A/B gearing
  - xxx.xxxxxxxx multiplier

(8 places behind decimal point)

### Electronic Slip Clutch/Brake

- Variable Torque
- Wind/Unwind Applications

### Communications

- RS-485 @ up to 230K Baud
- ASCII, Binary, Modbus®, DMX512
- Host Control While Servo in Motion
- CANopen® (Rev 03 SW and higher)

### Programming Language

- Easy, Menu Driven Interface
- Command Parameter Prompts
- No Syntax Errors
- User Namable I/O and Registers

### Advance PVIA™ Servo Loop

- Improvement Stability
- Simulated Viscous Inertial Damper
- 100:1 Inertial Mismatch
- Direct Drive Oversized Inertial Loads
  - Flywheels
  - Belt Drives
  - Typically eliminates need for Gearheads

### Anti-Hunt™

- Optionally transition to open loop while in position – automatically changes back to full servo if position is disturbed.
- No Servo Dither While at Rest

### Multi-Task/Multi-Thread

- Two programs plus a motion simultaneously
- Multiple background protection settings

### Based on QCI's Hybrid Servo Motors:

#### NEMA 34 Frame

- 16000 Counts/Rev Encoder
- Up to 2600 oz-in (18.6 Nm) (continuous)

SMI Interface – Processor power, IO, Serial Communications

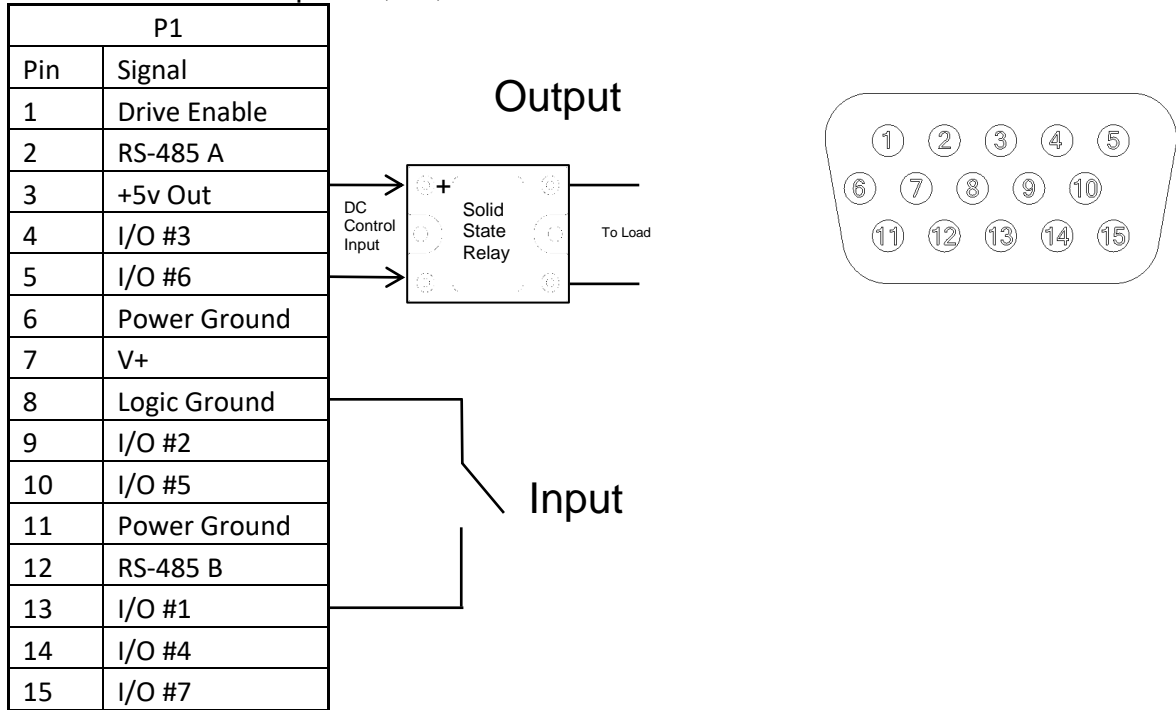

**Input Power**

**Processor Power**

V+ Processor: +12 VDC to +48 VDC, regulated. Processor Power should have no larger than an 8A fuse to limit power.

**Driver Power**

V+Driver: +12 VDC to +72 VDC. Device must be initialized for the actual operating voltage. Driver Power, Power Ground, Chassis Ground, Clamp+ and Clamp- are provided on a separate 5 pin 5W5 connector: The Driver power should be fused with not more than a 25A slow blow fuse unless power supply current is limited to same.

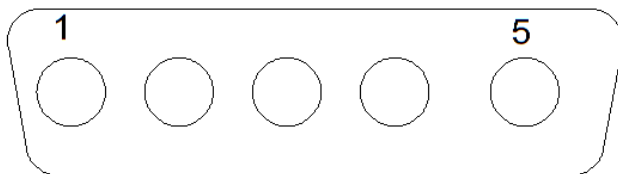

Pin	Signal	Wire color for QCI-XC-P10
1	V+ Clamp	Yellow External Clamp resistor (according to need)
2	V+ Driver	Red Normal V+ connection
3	V- Clamp	Orange External Clamp resistor (according to need)
4	V- Driver	Black Normal V- Connection
5	Chassis Gnd	Drain1,2

### **Built-in Clamps**

Two stages of Clamp circuits are built into the system. The primary clamp allows the clamp resistor to be mounted external to the system for easy heat elimination. This provides for very large inertias and for systems that are back driven. The secondary clamp provides up to 50W average clamping, and comes on at a slightly higher voltage than the primary clamp, actuating only if the primary clamp is not sufficient or is not connected (or opens). The secondary clamp includes over temperature monitoring to shut down the motor if the internal resistors are dissipating excessive energy. Connecting the V+ Clamp and the +VP signals together will bypass the internal clamp, allowing regenerated power to be used to recharge batteries, for example. Care must be taken to prevent overvoltage.

### **Driver Power Input Current**

20 Amps DC maximum for any input voltage, +12.5 VDC to +72 VDC per controller. This input must be fused no more than 25A slow blow. The Driver Power is isolated from the processor power to minimize the influence of the high currents for the driver upon the input voltages.

### **The processor power and the driver power isolation**

The processor power and driver power are galvanically isolated. The processor ground, the driver ground, and the chassis ground should be connected at the power supply, with the negative side of the power supply strapped to chassis ground at that point, for best noise characteristics.

## **Inputs & Outputs**

### **Digital Inputs**

0 to +3.3 VDC. LVTTTL level compatible. All inputs have a light pull-up (~100k ohm to 3.3v). All I/O have an optional programmable pull-up/pull-down of 2.2 k ohm; the source to these resistors may also be floated if no pull-up or pull-down is needed. The seven IO are protected to +/- 40v.

### **5v output**

Rated to 100mA. Do not back drive. Do not short out.

### **Digital Output Voltage**

0 / +3.3 VDC.

### **Digital Output Current**

Sinking or Sourcing: 2mA

### **Analog Inputs**

All 7 I/O may be used as Analog Inputs: 0 to +3.3 VDC input signal range.

IO7 has a secondary circuit to handle 0 to +10v input signal range; the input protection will isolate the normal 3.3 v input channel allowing the 0 to 10v operation.

Resolution: 12 bits (before filtering)

Analog signals are read every servo cycle (120  $\mu$ sec.) and the converted analog data is processed through a (default) 5 ms filter to reduce noise & transients.

**Drive Enable Input**

This hardware drive enable input must be connected to +10 VDC to +48 VDC for the drive electronics to be enabled. The Drive enable voltage is measured with respect to the processor power ground, not the driver power ground.

**Communications**

**Serial Interface**

RS-485 multi-drop, Reduced unit load accommodates up to 255 nodes.  
Protected up to +/- 70v.

Note: RS-485 requires a nominal 120 ohm 1/2 W termination resistor at each end of the network for longer runs. This termination is not provided onboard and must be provided by the user.

**Protocols**

8-bit ASCII, 9-bit binary, Modbus®, and DMX512

**Hardware Configuration Settings**

Available Baud Rates: 2400, 4800, 9600, 19.2k, 28.8k, 57.6k, 115.2k or 230.4k  
(250k only for DMX512)

Data Bits: 8 (9 bits for binary)

Stop Bits: 1.5 or 2

Parity Bit: None (Modbus supports None, Even, Odd)

**CAN interface**

**CAN connections**

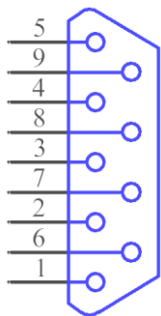

The CANopen connections are made via a 9 pin male DSub connector.

- 2 = CAN-L
- 3 = GND
- 6 = GND
- 7 = CAN-H

The CAN bus connection is not isolated, but does include transceivers which have an extended +/- 70v fault protection range. The CANopen® communications protocol allows the unit to function as a master, slave, or peer on a CANopen network. See the CANopen User Manual for details on the CANopen protocol. This protocol operates simultaneously and independently from the standard serial protocols.

Note that a 120 ohm 1/2 W termination resistor is required at each end of the CAN network (only two per system). This termination is not provided onboard the controller and must be provided by the user. For the CAN bus operation, this termination is **not** optional.

CANopen® and CiA® are registered community trademarks of CAN in Automation e.V.

## Wiring and Cable Specifications

### Encoder Feedback Connection: 8-Wire Encoder Cable

Designation	Wire Color	Wire Gauge
Encoder +5V	Red	26 AWG
Encoder Gnd	Black	26 AWG
Encoder A+	White	26 AWG
Encoder A-	Yellow	26 AWG
Encoder B+	Green	26 AWG
Encoder B-	Blue	26 AWG
Z+ (index +)	Orange	26 AWG
Z- (index -)	Brown	26 AWG

- For a back mounted encoder, the encoder's A Channel should lead B Channel when the front motor shaft rotates clockwise.

#### Encoder Cable Specifications

Nominal Cable Diameter =	0.25 inches
Minimum Bend Radius =	1.8 inches
Each Wire Pair Has A Shield	
Shields Connected To SilverNugget Case	

### Driver Winding Signals: 4-Wire Motor Cable

Designation	Wire Color	Wire Gauge
Winding A+	Red	14 AWG
Winding A-	Yellow	14 AWG
Winding B+	Black	14 AWG
Winding B-	Orange	14 AWG
Drain †	Bare Wire	2x16 AWG ‡

#### Motor Cable Specifications

Nominal Cable Diameter =	0.4 inches
Minimum Bend Radius =	2.8 inches
Wire Pairs Are Not Shielded	
Each Wire Pair Wrapped with 16 AWG Drain Wire	

† The Drain is connected to the SilverNugget case. QCI recommends connecting the Drain to the motor chassis.

‡ The Drain is composed of two 16 AWG wires in parallel.

## Stepper Motor Wiring Configuration

Ideally, the SilverNugget will be interfaced with a four wire bipolar motor. Then the SilverNugget four wire motor cable will match up with the leads from the micro-step motor. Although, the SilverNugget will work with motors that have more than 4 wires.

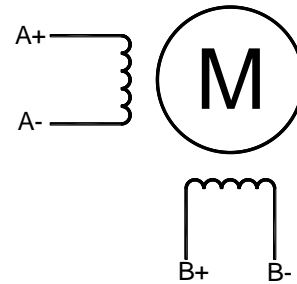

4 Wire Bipolar Configuration

Some bipolar micro step motors are 8 wires. Typically, an eight wire motor is wired in a parallel configuration for use with the SilverNugget. However, a series wiring configuration is acceptable. Either configuration is perfectly legitimate to obtain the best motor characteristics and achieve optimum performance.

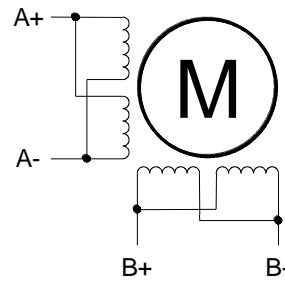

8 Wire Parallel Bipolar Configuration

manufactured with

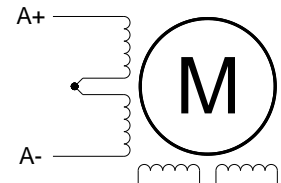

8 Wire Series Bipolar Configuration

Unipolar motors are not suggested with the SilverNugget, as they are typically higher inductance and higher resistance than equivalent bipolar configurations.

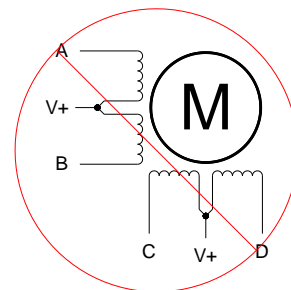

Unipolar Configuration

**SilverNugget Part Number Cabling Interface Designation:**

**QCI-N2-MX-BB01**

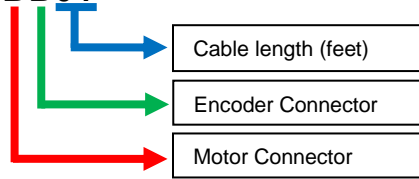

The first letter specifies the type of connector placed on the end of the motor cable. The second letter specifies the type of connector placed on the end of the encoder cable. Options for the motor and encoder cable are interchangeable. For example, ordering a SilverNugget, with the ABxx option, would mean the motor cable has flying leads and the encoder cable has a TE or Molex compatible connector.

Cable lengths are available from 1 foot to 25 feet in one-foot increments. For longer lengths, contact QCI Support.

**A** – Cable has flying leads.

The AA option comes with flying leads on both the Motor and Encoder cables.

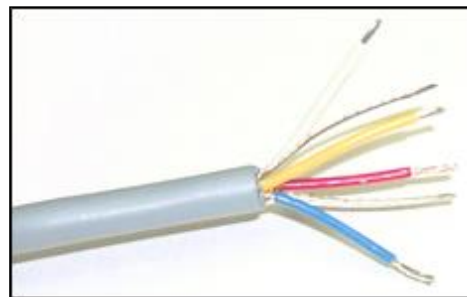

**B** –

**Motor Cable:** 5-pin Single Row Socket Connector

- TE or Molex compatible connector, with crimped pins, attached to end of cable.

**Encoder Cable:** 10-pin Dual Row, 0.1" Socket Connector

- Molex compatible connector, with crimped pins, attached to end of cable.

The -BB option (standard SilverNugget N3-MX option) comes with a TE or Molex compatible connector on the motor cable and Molex compatible connector on the encoder cable.

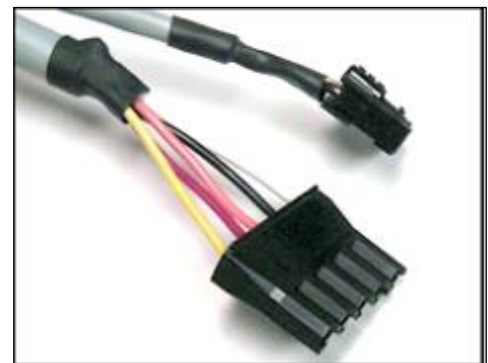



**B Option on Motor Cable**

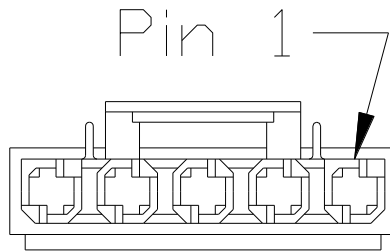

Motor Cable Connector Face View.

Pin Number	Signal	Wire Color
1	Winding A-	Yellow
2	Winding A+	Red
3	Winding B-	Orange
4	Winding B+	Black
5	Chassis Gnd	Green/Yellow

A short length (approx. 1 inch) of 16 AWG wire is soldered between the Drain and the Chassis Ground Pin on the SilverNugget B option motor connector.

**Motor Cable Connector Part Numbers**

Description	Molex Part #	Series	Total Used
Housing	44441-2005	44441	1
Female Pins	43375-1001	43375	5

**Recommended Crimping Tool**

Description	Molex Part #	Series
Crimper	63811-7300	63811

**Mating Connector Part Numbers**

Description	Molex Part #	Series	Total Used
Housing	43680-2005	43680	1
Male Pins	43178-2002	43178	5

**Recommended Crimping Tool**

Description	Molex Part #	Series
Crimper	63811-3100	63811

The 43375 and 43178 series pins, with 14 AWG wire, are rated for 18 Amps each.

**B Option on Encoder Cable**

The B option for the encoder cable interfaces with a US Digital 10 pin, dual row differential encoder connector.

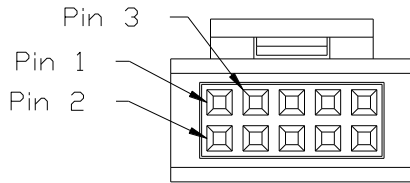

Encoder Cable Connector Face View.

Pin Number	Signal	Wire Color
1	Not Used	
2	Encoder Gnd	Black
3	Z- (Index -)	Brown
4	Z+ (Index +)	Orange
5	Encoder A-	Yellow
6	Encoder A+	White
7	Encoder +5V	Red
8	Not Used	
9	Encoder B-	Blue
10	Encoder B+	Green

**Encoder Cable Connector Part Numbers**

Description	Molex Part #	Series	Total Used
Housing	15-04-5104	70013	1
Insert	22-55-2103	70450	1
Female Pins	16-02-0104	70058	8

**Mating Connector Part Numbers**

Description	Molex Part #	Series	Total Used
Housing	50-65-0010	70022	1
Insert	22-55-2103	70450	1
Male Pins	16-02-0117	70021	8

- The 70058 and 70021 series pins, with 26 AWG wire, are rated for 1.8 Amps each.

**Recommended Crimping Tool**

Description	Molex Part #
Crimper	11-01-0208

## STATUS LIGHTS

Three status lights are provided on the back of the SilverMax. The Comm LED (normally Red) indicates the unit is ready (no program running) by a dim level, it is off between communications if a program is running. It blinks brightly during each incoming communications frame. The Status light (normally Green) varies in intensity with the motor torque (negative torque dimmer, positive torque brighter); if Done Bit is configured the LED lights to indicate Done (See Set Done Bit command), is also used to blink error codes if a fault is detected (and the Done bit is not configured). The Driver power present LED is normally Green; It becomes amber if driver is disabled (either by hardware or by software).

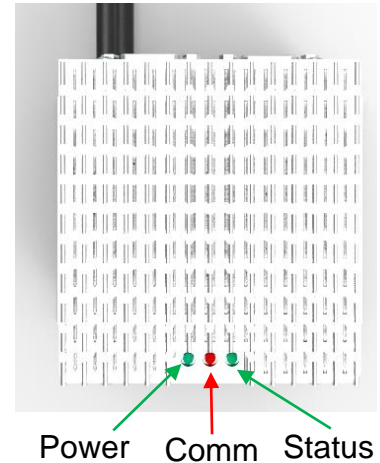

## Environmental Specifications

### Operational Temperature

-40 C to +70 C. Continuous torque curves taken at 20C; derating may be needed at higher temperatures. 100% torque requires motor affixed to thermally conductive structure, and may need air flow. Must be verified in final application.

### Storage Temperature

- 40 C to +85 C

### Humidity

Continuous specification is 95% RH non-condensing.

### Shock

Limitation is approximately 50g/11ms.

Specifications subject to change without notice. See [www.QuickSilverControls.com](http://www.QuickSilverControls.com) for current information.

### Mechanical Dimensions

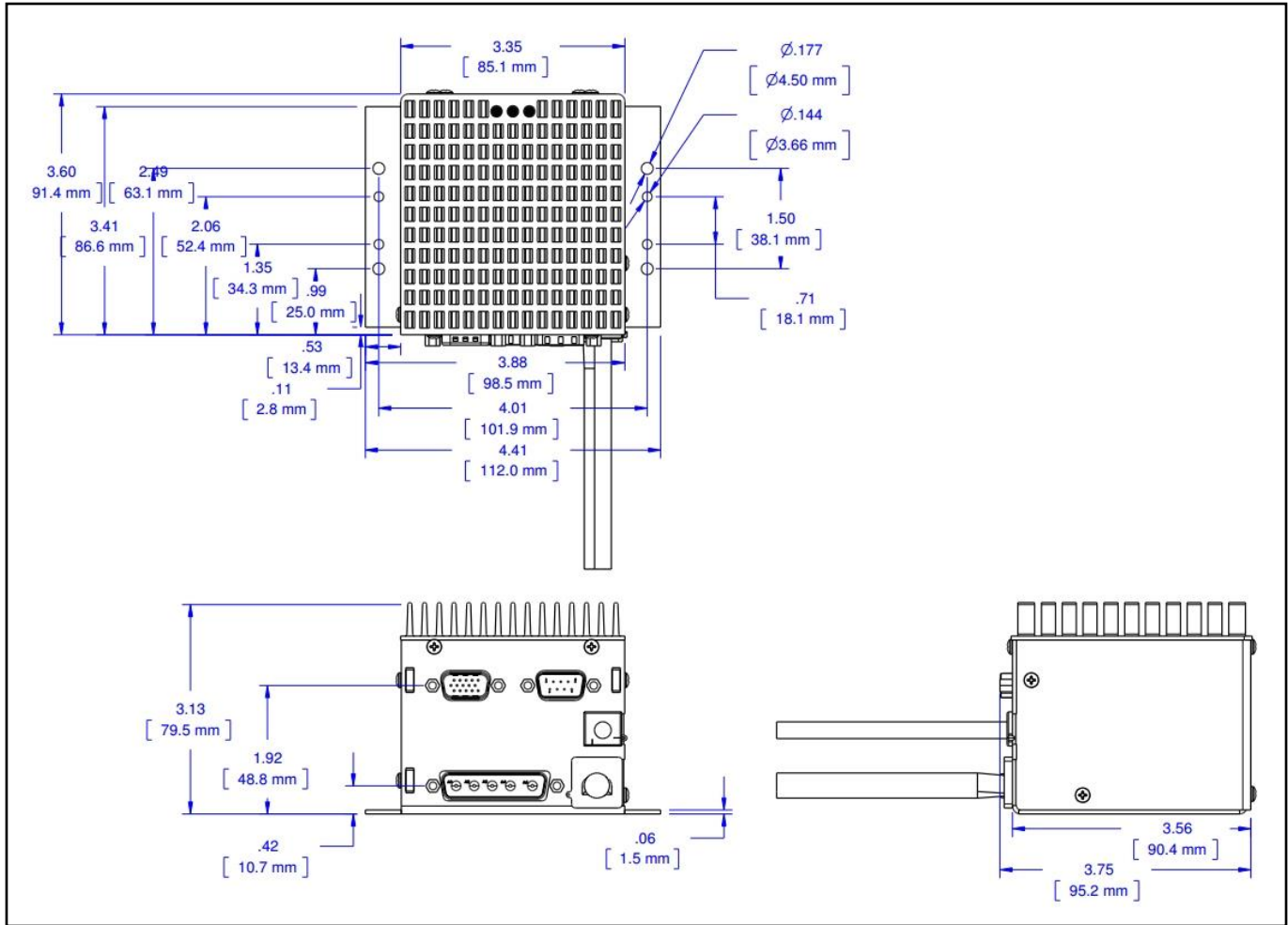

## Recommended Components

### SilverNugget N3-MX Start-Up Materials

For first time users, QCI recommends purchasing the following items to aid with use of the SilverMax X-series servo motor:

- SilverNugget N3 X-series Breakout Board (QCI-BO-X3)
- USB to RS485 converter (QCI-USB-RS485)
- Desired 3<sup>rd</sup> party motor with 1000, 2000, or 4000 line encoder.
  - Contact factory for more supported encoder resolutions.
- 10' Power cable (QCI-EC-P10)

Optionally:

1000W, +48V Power Supply (SE-1000-48)

- Power Supply Cord w/ Flying Leads (QCI-C-ACP-FLY-6)
- 50W Clamp Resistors (QCI-R4-50) (may need multiple in series/parallel for needed dissipation – contact Support for more details)

Configuration Software: QuickControl™ is free and available from our website.

### Typical System Setup

Note: Power cable is not fused as the power supply is current limited to ~20A; higher power supplies or batteries require a fuse in the positive lead.

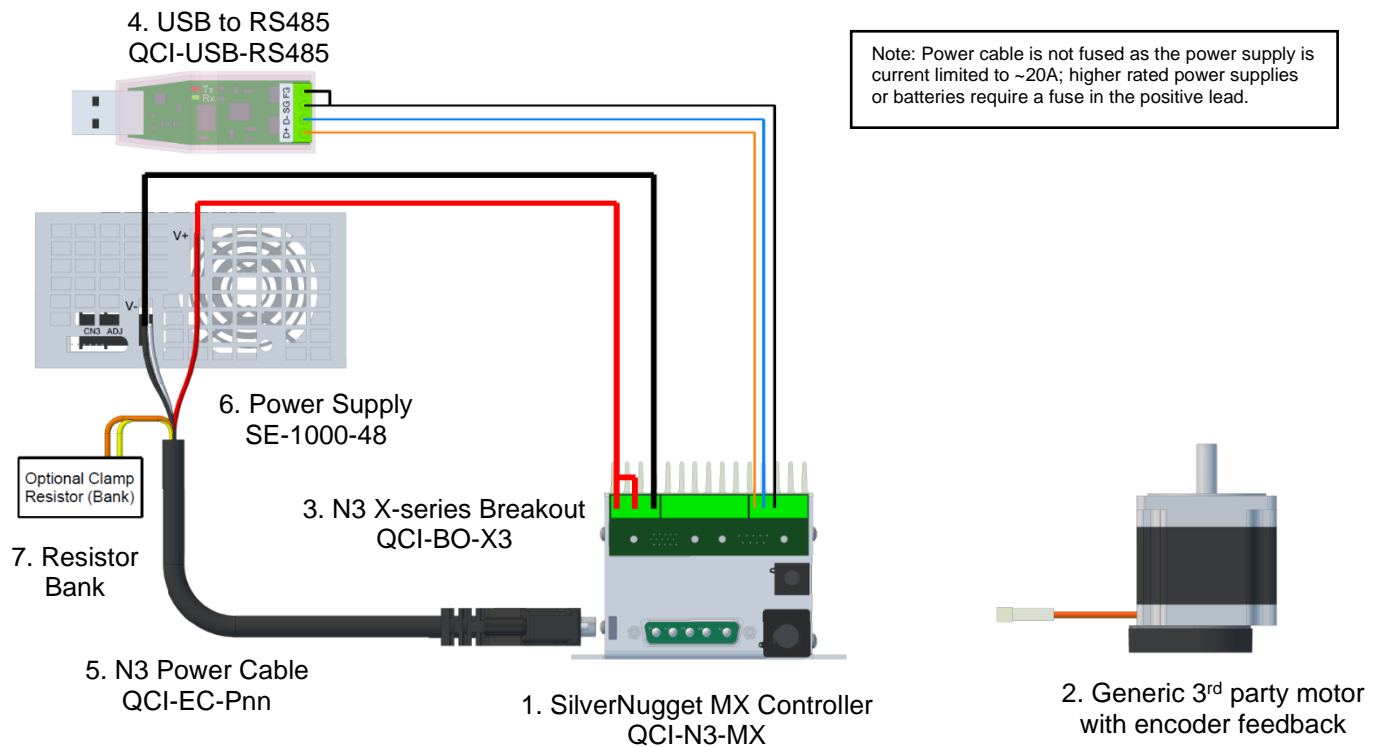

### 1. SilverNugget MX controller

Controller with digital driver and integral Clamp.

## 2. Generic 3rd Party Micro Step Motor with Encoder Feedback

SilverNugget N3-MX is specifically designed to drive 100 poles, 1.8° step motors. To best utilize the capabilities of the SilverNugget, select a motor that has been optimized for micro stepping.

## 3. Breakout (QCI-BO-X3)

The breakout board breaks out the SilverNugget N3's processor power input, drive enable input, RS-485 communication lines, 7 LVTTL digital/analog I/Os, local +5v supply, and CAN bus onto pluggable terminal connector blocks.

## 4. USB to RS485 Converter (QCI-USB-RS485)

USB-RS-485 converter provides a USB powered serial port with RS-485 signaling. See [QCI-TD073](#) USB-RS485 Converter Setup Guide for information on network termination and shielding recommendations.

## 5. SilverNugget Power Cable (QCI-EC-Pnn)

This connector provides power conductors for V+, V-, and Clamp resistor, in addition to a chassis ground connection.

## 6. Power Supply

Power supply selection is motor dependent, but the following will work with all SilverNugget X-series controllers.

SE-1000-48 (48V, 20A, 1000 Watt)

RS-1000-48 (48V, 20A, 1000 Watt)

## 7. External Regenerative Clamp Resistor

Rapid deceleration of larger loads may require the use of the Primary Clamp circuit, requiring adding external power resistors between Clamp+ and Clamp-. Do not connect Clamp- to Clamp+ except through a clamp resistor of sufficient power rating. Resistance should be such that at operating voltage the resistor current will not exceed 20A when the clamp is active.

## Changes from N3 E-series:

For users replacing SilverNugget E-series, see the [N3 Product Change Notice](#) for a full description of software and hardware changes.

## Part Numbers

SilverNugget MX	
	X-Series M-Grade controller with cables for encoder and Motor. A single firmware version handles varying encoder division (including none) and different encoder index styles; these are configured at initialization time. The single version firmware also handles ASCII, Modbus, 9Bit, DMX, CANopen.
QCI-N3-MX-BB01	1 foot cables, Encoder cable has locking 10 pin connector compatible with differential US-Digital™ style encoders. Motor cable has 5 pin Molex/TE style connector
QCI-N3-MX-BB04	4 foot cables, Encoder cable has locking 10 pin connector compatible with differential US-Digital™ style encoders. Motor cable has 5 pin Molex/TE style connector
QCI-N3-MX-S0001	1 foot cables. Encoder cable has locking 10 pin connector compatible with differential US-Digital™ style encoders. Motor cable is flying lead only. Processor power is internally connected to Driver power (voltage limited to 48v).

## Contact Information

QuickSilver Controls, Inc.  
 990 N Amelia Ave  
 San Dimas, CA 91773  
 +1 (909) 599-6291 or (888) 660-3801  
 +1 (909) 599-6289 FAX  
[www.QuickSilverControls.com](http://www.QuickSilverControls.com)