

RS-232 To RS-485 Interface Module

This document is for use with the:

- RS-232 to RS-485 Interface Module (QCI-RS485)

Performance Characteristics

DC input voltage minimum	+9 VDC
DC input voltage maximum	+50 VDC
DC input current nominal (+V input)	45 mA
DC input current maximum (+V input)	250 mA
ESD static discharge (A/B)	1500 V
BAUD Rate maximum	115.2 kbps
BAUD Rate minimum	2400 bps
Number of "half power" nodes	64
Number of "full power" Std. RS-485 nodes	32
Maximum cable length	Over 4000 feet †
Termination resistance	120 ohms
RS-485 line driver	LTC1487

† All networking cable guidelines must be strictly followed (shields, grounding, termination, etc.) The BAUD rate must be lowered to achieve long distance cable runs.

Connectors

RS-232 (DB25 connector)

- RS-232 TxD transmit (output): DB25 pin 2
- RS-232 RxD receive (input): DB25 pin 3
- RS-232 Ground (input/output): DB25 pin 7

Optional RS-232 Connections:

- RS-232 RTS (output): DB25 pin 4
- RS-232 CTS (input): DB25 pin 5

RS-485 (Terminal Strip)

All Lines Required For Proper Operation

- V+ and V-: Input Power (+9 to 50 VDC)
- Shld / Gnd: Logic Ground
- A and B: RS-485 Communications Lines

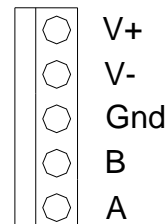

RS-232 Communication Settings

The communications settings for the device attached to the RS-232 side of the interface module (i.e. PC or other host) are as follows:

- No Parity
- 8 Data Bits
- 1.5 or 2 Stop Bits
- Flow Control None

RS-485 Communication Settings

The communications settings for the devices attached to the RS-485 side of the interface module (i.e. SilverLode controllers) are as follows (see Command Reference for more details):

- Serial Interface (SIF): 1 (RS-485)
- ACK Delay (ADL):

ADL (ms)	Baud Rate
2.8	115200
3.2	57600
4.2	28800
5.2	19200
8.1	9600

NOTE: The interface module has an Auto Transmit feature that seizes the RS-485 communication lines as soon as it detects data on the RS-232 transmit line. The module releases the RS-485 lines after it see no RS-232 data for some period of time. RS-485 devices must allow for this by waiting some time between receiving and transmitting data. QCI devices do this with the ACK Delay (ADL) command.

LED Operation

The QCI-RS485 interface module provides a bi-color diagnostic LED to aid in cabling problems and general operation. Since this LED is powered only when data is present, it may be illuminated for somewhat brief periods. Also, if transmit and receive are closely spaced, the bi-colored LED may take on an orange hue when rapidly switching from RED to GREEN.

LED	Description
LED OFF	No receive or transmitted data present
LED RED	RS-232 transmit
LED GREEN	RS-485 receive

BUS Termination Jumpers

The interface module is supplied with jumpers to enable and disable termination. The two RS-485 nodes at the extreme ends of the cable require termination.

- JP1 and JP2 In - Active Termination
- JP1 and JP2 Out - No termination

Active termination is important as it guarantees a stable RxD signal and no false start bits!

Ensure that only the two ends of the cable (or network) are terminated. Excessive termination will result in extreme line load and thereby adversely affect data transmission.

RS-485 Multi-Drop Wiring

RS-485 is sometimes termed as RS-485 multi-drop LAN since it allows connecting several devices in a local area network (LAN) environment. All the devices on the LAN are connected to a specific wire pair. Transmit and receive lines share the same two wires.

Most industry RS-485 specifications limit the network to only 32 nodes (devices) when using full load receivers. However, IC manufacturers have developed 1/2 load RS-485 receivers allowing this limit to be extended to 64 nodes on the RS-485 LAN. The ends of the network lines require passive termination resistors between the lines. The resistance must match the impedance of the twisted pair, commonly 120 ohms. At least one line of the pair must have active biased termination to guarantee the marking signal level is in idle state when no devices are transmitting. The QCI-RS485 interface conveniently provides active and passive bias termination for easily connecting directly to SilverLode controller/drivers (SilverNugget or SilverDust).

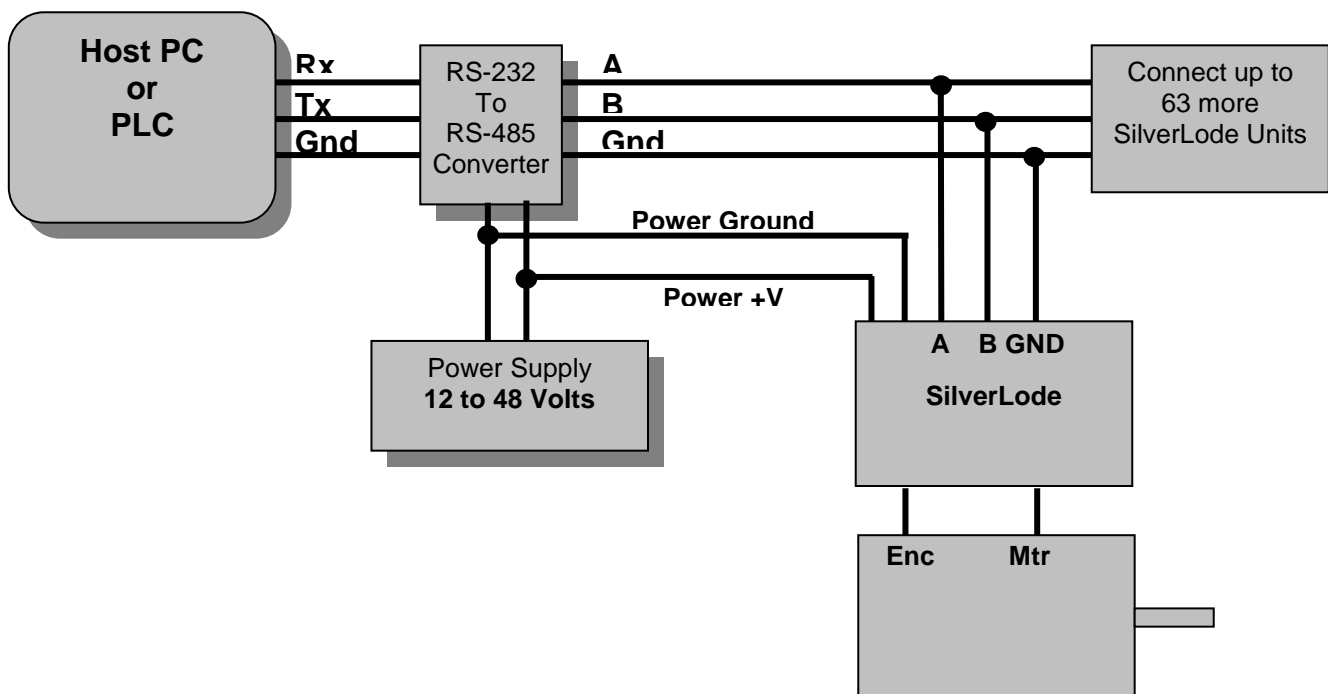

QCI-RS485 Mechanical Dimensions

All values are in inches (± 0.05)

